

Extended Piston Vibrators for Bulk Bag Unloading

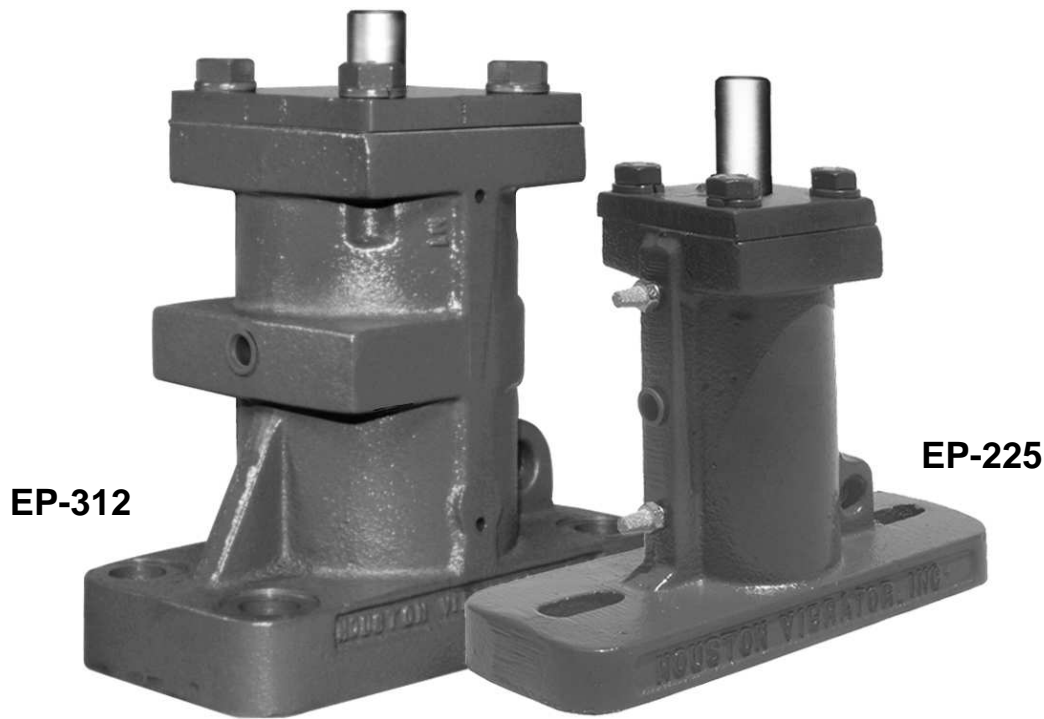
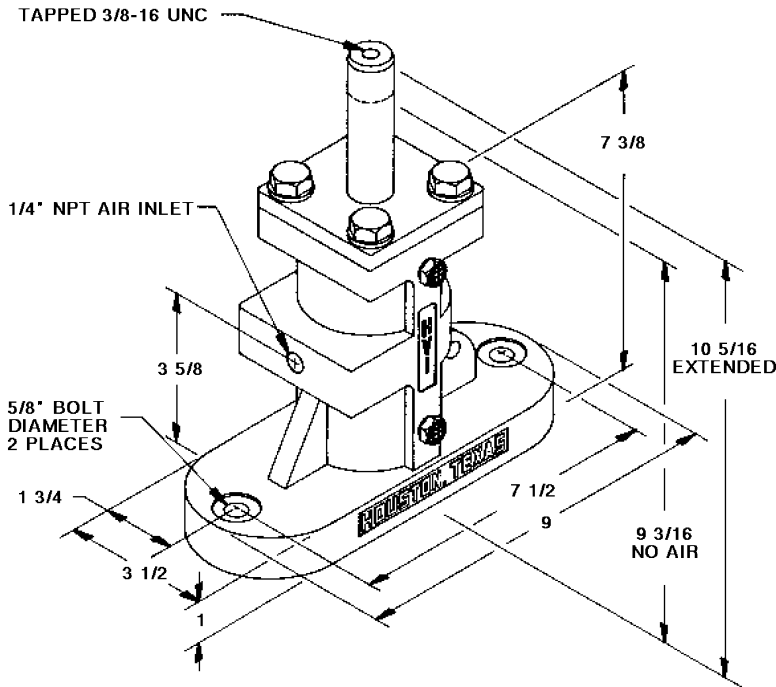

If stubborn material in bulk bags is causing problems in your bulk bag unloading area, try an EP Series Extended Piston Vibrator.

The EP Series is specifically designed for keeping materials flowing from bulk bags, portable “day bins” and batch feed hoppers. The piston extends through the head plate, and is threaded to accommodate a connecting rod or bumper. Spring returns and dual air exhaust mufflers are standard on all EP Series models. The air-cushioned piston provides the force needed to dislodge stubborn materials with low noise levels. Force and frequency are fully adjustable by varying the supply air pressure.

When used with a Lubro-Control Unit, available from Houston Vibrator, EP Series Extended Piston Vibrators are virtually maintenance free. Use of a pneumatic or electronic timer will also allow timed action from your EP Series vibrator without constant attention of an operator. Ask your salesperson about installation kits and mounting and control components for your installation.



EP-225 Data

Vibrator Weight:
18 Lbs.

Piston Weight:
4 Lbs.

Frequency (VPM):
2200 @ 60 PSI

Air Consumption:
8.5 CFM @ 60 PSI

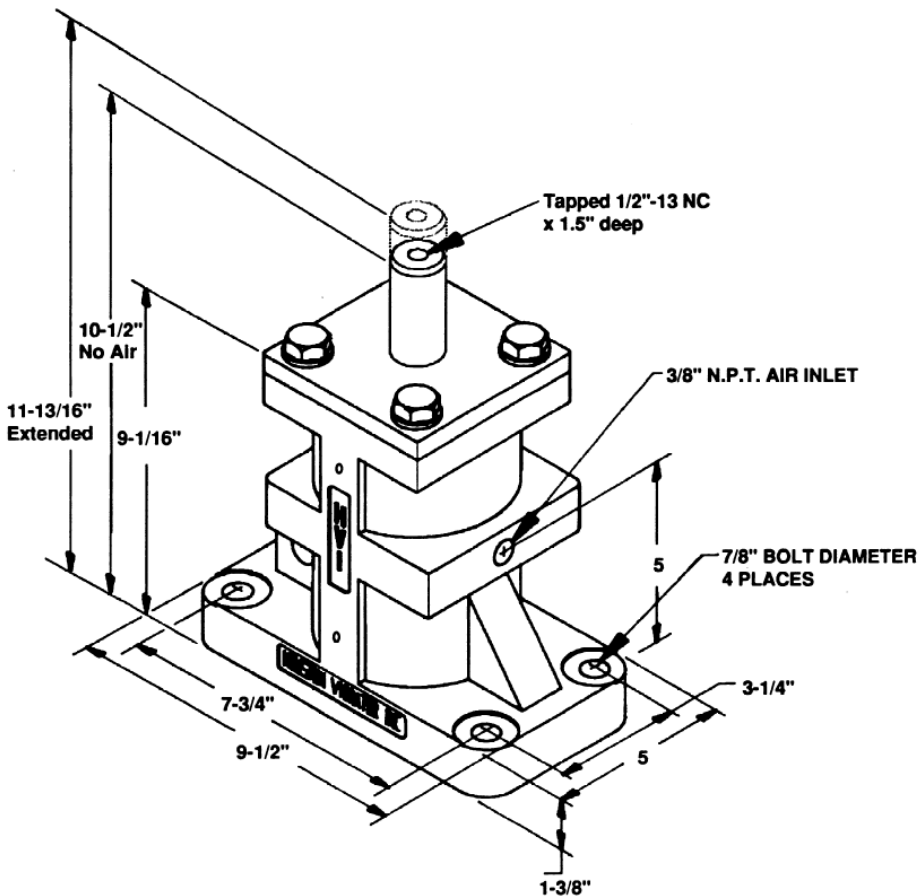

EP-312 Data

Vibrator Weight:
54 Lbs.

Piston Weight:
11.3 Lbs.

Frequency (VPM):
1800 @ 60 PSI

Air Consumption:
14.2 CFM @ 60 PSI